

- A** – Stainless Steel, Flexible Discs
- B** – Overload Collars
- C** – Anti-Corrosion Treatment
- D** – Axially Split Spacer for Ease of Maintenance
- E** – Self-Locking Fasteners
- F** – Compression/Jacking Bolt Feature
- G** – Hubs Designed for Short DBSE

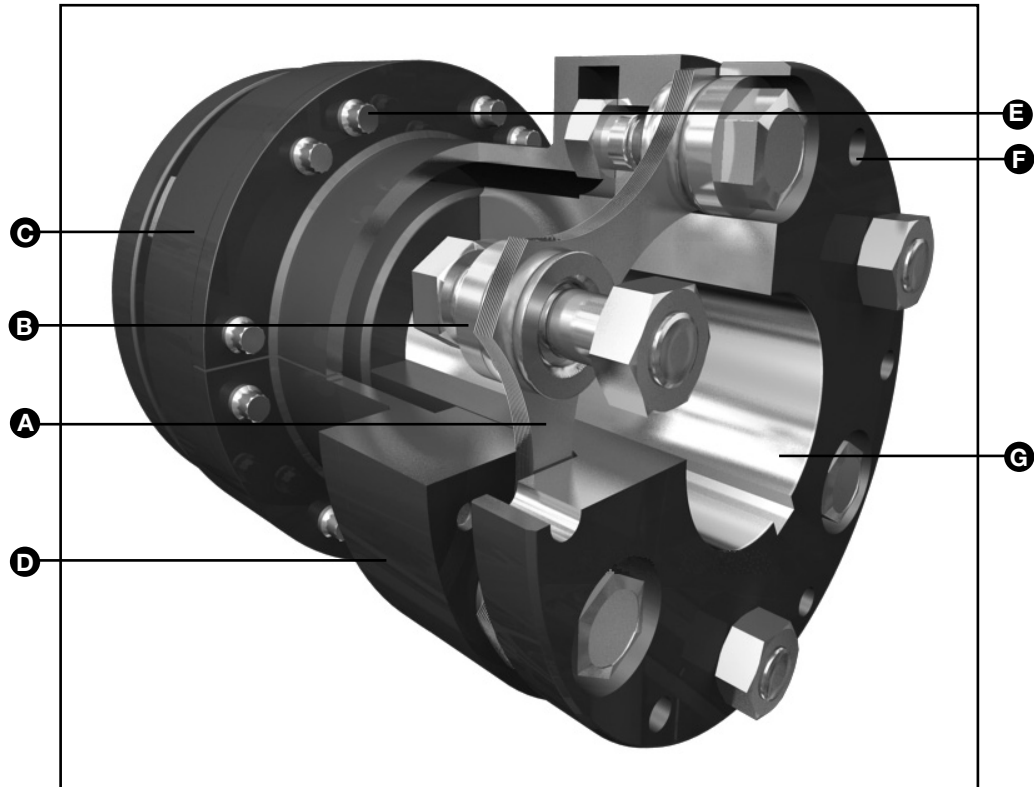

### Product Description

John Crane's Metastream® TSE range of membrane couplings has been specifically designed to provide a solution for close coupled machinery. The key benefit of this coupling is the ability to replace flexing discs without the need to move either of the connected machines.

- Easy maintenance without moving machines
- Close coupled DBSE, fully variable from 0.125" upwards
- Coated carbon steel for corrosion protection
- Choice of hub configuration to suit DBSE

### Design Features

- **Fit and Forget** - Designed for infinite life and, with correct machinery alignment, will outlast the machines it is connected to
- **Overload Protection** - Fitted with overload collars to protect the discs in the event of severe torsional overload
- **Low Imposed Loads** - Designed to optimize their torque capability, while minimizing the reaction forces due to misalignment
- **Zero Maintenance** - Requires no lubrication or routine maintenance
- **Ease of Assembly** - Can be replaced without moving the connected machines
- **No Backlash** - Ensures that there is zero backlash, making the coupling ideal for drives such as machine tool indexers, printing presses, packing, and all applications where constant speed is crucial

# TYPE TSE

## CLOSE COUPLED T SERIES COUPLING

### TSE Technical Data

Coupling Size	Rating HP/100 rpm	Max. Continuous Torque lb-in	Peak Overload Torque lb-in	Max. Speed rpm	Complete Coupling (Blank Bore)	
					Weight lb.	Moment of Inertia lb-in
0075	10	6,300	15,750	8,700	18.4	47
0135	18	11,340	28,350	7,500	30.1	111
0230	31	19,520	48,800	6,400	51.5	276
0350	47	29,600	74,000	5,800	74.8	507
0500	67	42,200	105,000	5,200	105.3	902
0740	99	62,360	155,900	4,800	145.0	1566
0930	125	78,740	196,850	4,500	190.6	2455
1400	188	118,440	296,100	4,000	255.3	4049

### Typical Arrangement

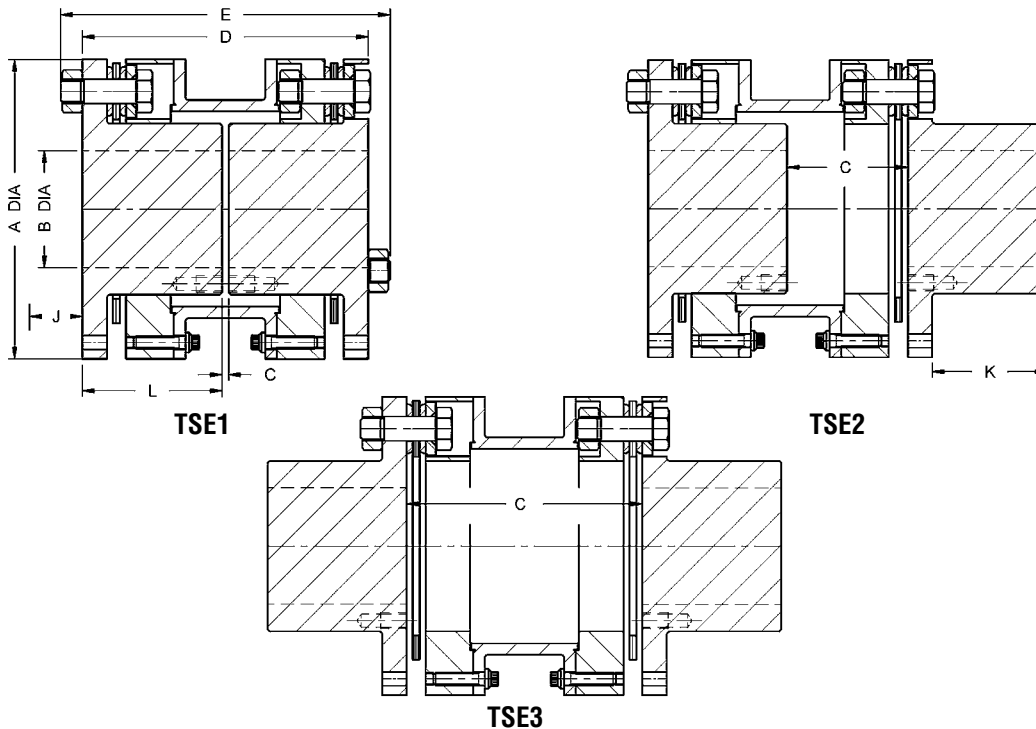

### Dimensional Data (Inches)

Coupling Size	A	B Max. Bore	C					D	E	J	K	L	
			TSE1 Std.	TSE1 Max.	TSE2 Std.	TSE2 Max.	TSE3					Max.	Min.
0075	4.84	1.75	0.125	2.21	2.17	3.21	4.22	5.00	5.69	1.91	2.05	2.44	1.40
0135	5.76	2.25	0.125	1.91	2.34	3.23	4.56	5.51	6.34	2.05	2.22	2.69	1.80
0230	6.97	2.75	0.188	2.03	2.76	3.68	5.33	6.43	7.36	2.72	2.57	3.12	2.20
0350	7.81	3.19	0.188	2.08	3.06	3.96	5.93	7.19	8.31	2.81	2.87	3.50	2.60
0500	8.78	3.56	0.188	2.25	3.36	4.34	6.53	7.95	9.22	2.89	3.17	3.88	2.90
0740	9.88	3.94	0.250	2.45	3.71	4.76	7.18	8.75	10.08	2.92	3.46	4.25	3.20
0930	10.79	4.50	0.250	2.43	4.07	5.16	7.90	9.63	11.13	4.00	3.82	4.69	3.60
1400	12.00	4.56	0.250	3.07	4.36	5.73	8.48	10.37	11.88	4.01	4.12	5.06	3.70

Notes:

- 1 Dimensions should not be used for construction. Certified dimensions furnished upon request.
- 2 Weight and inertia values based upon minimum Distance Between Shaft Ends (DBSE) and unbored hubs.
- 3 Maximum bores are based on standard AGMA square key dimensions.
- 4 Dimension J is minimum required for field repair.

### Selection Procedure

1. Select appropriate service factor SF from table.
2. Calculate coupling rating R from:

$$R = \frac{HP \times 100 \times SF}{N}$$

**Where:**

HP = driver rated power  
 N = speed (rev./min)

3. Select a coupling with the same or higher rating.
4. Check that the hub bore capacity is suitable, if not select a larger size coupling.
5. Check peak torque capability is suitable for application.
6. Check speed capability.
7. Specify Distance Between Shaft Ends (DBSE).

**Example:**

250 HP electric motor connected to centrifugal pump at 3600 rpm with a 0.25 inch DBSE.

$$SF = 1.0$$

$$R = \frac{250 \times 100 \times 1.0}{3600}$$

R = 6.9 HP per 100 rpm

**Selection: TSE1 – 0075**

Maximum parallel shaft bore is 1.75"  
 Peak torque capability .....15,750 lb.-in.  
 Maximum speed capability is 8,700 rpm.  
 Coupling does not normally require additional balancing.

Designation — **TSE1 - 0075 - 00## - 0064**

### Service Factor SF

Suggested service factors for electric motor, steam turbine, and gas turbine drivers are given below.

Torque Variation	Typical Application	Service Factor
Constant Torque	Centrifugal Pump Centrifugal Compressor Axial Compressor Centrifugal Blower	1.0*
Slight Torque Fluctuation	Screw Compressor Gear, Lobe and Vane Pumps Forced Draft Fan Medium Duty Mixer Lobe Blower	1.5
Substantial Torque Fluctuations	Reciprocating Pumps Heavy Duty Mixers Induced Draft Fans	2.0

\*Use a minimum service factor of 1.25 on electric motor drives through a gearbox.

The examples given are for typical machines and are empirically based guidelines. Knowledge of actual torque characteristics may indicate a different service factor. Consult John Crane for advice.

KSelect is an internet based selection program for the TSE. This selection program provides all necessary technical data including inertias and torsional stiffness. Visit [www.johncrane.com](http://www.johncrane.com) to access this program.

### Available Options

- Spark-resistant couplings for hazardous zone operation.
- Special materials for low temperature applications and/or higher corrosion resistance.

Consult John Crane for any other special requirements. Metastream couplings can be adapted to suit virtually all power transmission coupling needs.

### Coupling Alignment

Correct installation and alignment of coupling is essential for reliable machinery performance.

John Crane supplies a variety of shaft alignment equipment and offers alignment training courses.

TSE - Misalignment Capabilities					
Coupling Size	*Max. Axial $\pm$ inches	Equivalent Thrust lb.	Max. Angular Degrees	Restoring Moment at Max. Angle lb-in/deg	**Max. Parallel $\pm$ inches
0075	0.06	81	0.5	156	0.034
0135	0.08	126	0.5	208	0.037
0230	0.10	166	0.5	260	0.043
0350	0.11	175	0.5	600	0.048
0500	0.13	243	0.5	720	0.053
0740	0.15	286	0.5	840	0.058
0930	0.17	331	0.5	960	0.064
1400	0.20	608	0.5	1080	0.068

These values are maximums for each type of misalignment. It is recommended that the coupling be initially aligned to 10% of these values to allow for inevitable movements during the life of the machines.

\* Meets NEMA end float specification without modification.

\*\* Values based on angular deflection of 1/2° per end.

The angular and axial restoring forces in the table below are given at maximum deflection. The chart can be used to determine forces across the full deflection range. The nonlinear characteristics can detune a system to prevent high amplitude axial vibration.

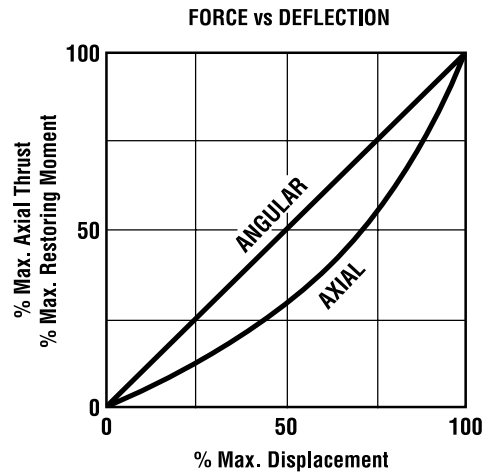

### Balance Recommendations

The inherent balance of the TSE range of couplings meets AGMA standard 9000-C90 class 8. The adjacent chart relates the coupling sizes to operating speeds on the basis of this AGMA class 8 characteristic to provide a general guide to maximum permissible speed. If higher speeds are required, contact John Crane for an alternative coupling selection.

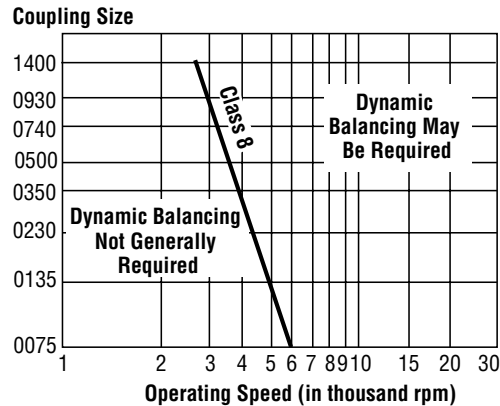

**North America**  
United States of America  
Tel: 1-847-967-2400  
Fax: 1-847-967-3915

**Europe**  
United Kingdom  
Tel: 44-1753-224000  
Fax: 44-1753-224224

**Latin America**  
Brazil  
Tel: 55-11-3371-2500  
Fax: 55-11-3371-2599

**Middle East & Africa**  
United Arab Emirates  
Tel: 971-481-27800  
Fax: 971-488-62830

**Asia Pacific**  
Singapore  
Tel: 65-6518-1800  
Fax: 65-6518-1803

If the products featured will be used in a potentially dangerous and/or hazardous process, your John Crane representative should be consulted prior to their selection and use. In the interest of continuous development, John Crane Companies reserve the right to alter designs and specifications without prior notice. It is dangerous to smoke while handling products made from PTFE. Old and new PTFE products must not be incinerated. ISO 9001 and ISO 14001 Certified, details available on request.